

**PAVER DETAILS**

**PAGE #**

PAVER SIZES	2
CALARC PAVERS - GENERAL DETAILS	3
LARGE SCALE CALARC PAVERS - GENERAL DETAILS	4-6
MADERASTONE® PAVERS	7-8
HEXAGONAL PAVERS - GENERAL DETAILS	9-11
ASHLAR PATTERN GUIDE	12
RANDOM PATTERN GUIDES	13-14
NARROW MODULAR PAVERS-GENERAL DETAILS	15
NARROW MODULAR PAVERS-FALSE JOINT	16
NARROW MODULAR TILE	17
WAVE PAVER 4" X 12" X 4"	18
DIAMOND PAVER 2 1/2" THICKNESS	19-21
DIAMOND PAVER 4" THICKNESS	22-24
SONORASTONE® PAVERS - GENERAL DETAILS	25
BORDERSTONE™	26
ALIGNED TRUNCATED DOME PAVER	27
DIRECTIONAL PAVER	28

**CALARC® PAVER SIZES\*:**

8" X 16" X 2"	12" X 12" X 2" 12" X 24" X 2"	16" X 16" X 2"	18" X 18" X 2" 18" X 24" X 2" 18" X 36" X 2"	24" X 24" X 2"
---------------	----------------------------------	----------------	--	----------------

**LARGE SCALE CALARC® PAVER SIZES\*:**

6" X 12" X 2 1/2"	8" X 16" X 2 1/2"	12" X 12" X 2 1/2"	18" X 18" X 2 1/2"	24" X 24" X 2 1/2"
6" X 18" X 2 1/2"	8" X 24" X 2 1/2"	12" X 18" X 2 1/2"	18" X 24" X 2 1/2"	24" X 36" X 2 1/2"
6" X 24" X 2 1/2"	8" X 36" X 2 1/2"	12" X 24" X 2 1/2"	18" X 36" X 2 1/2"	24" X 48" X 2 1/2"
6" X 36" X 2 1/2"	8" X 48" X 2 1/2"	12" X 36" X 2 1/2"	18" X 48" X 2 1/2"	24" X 60" X 2 1/2"
6" X 48" X 2 1/2"		12" X 48" X 2 1/2"	18" X 60" X 2 1/2"	
		12" X 60" X 2 1/2"	30" X 30" X 2 1/2"	36" X 36" X 2 1/2"

**HEXAGONAL PAVER SIZES\*:**

<u>WHOLE</u>	<u>FLAT HALF</u>	<u>POINT HALF</u>
16" X 2"	16" X 2"	16" X 2"
20" X 2 1/2"	20" X 2 1/2"	20" X 2 1/2"
24" X 2 1/2"	24" X 2 1/2"	24" X 2 1/2"

**NARROW MODULAR PAVER SIZES\*:**

3" X 9" X 4"	3" X 18" X 1" (TILE)		
3" X 12" X 4"	3" X 18" X 1 3/16" (TILE)	6" X 12" X 4"	12" X 12" X 4"
3" X 18" X 4"	3" X 18" X 2 1/2" (TILE)	6" X 18" X 4"	6" X 18" X 4"-FJ
3" X 24" X 4"		6" X 24" X 4"	6" X 24" X 4"-FJ

**DIAMOND PAVER SIZES\*:**

<u>CONNECTOR "A"</u>	<u>WHOLE</u>	<u>CONNECTOR "B"</u>
11 15/16" X 2 7/8" X 5 7/8" X 2 1/2"	23 7/8" X 2 7/8" X 5 7/8" X 2 1/2"	23 7/8" X 2 7/8" X 4 3/8" X 2 1/2"
11 15/16" X 3 7/8" X 7 7/8" X 2 1/2"	23 7/8" X 3 7/8" X 7 7/8" X 2 1/2"	23 7/8" X 3 7/8" X 5 7/8" X 2 1/2"
11 15/16" X 5 7/8" X 11 7/8" X 2 1/2"	23 7/8" X 5 7/8" X 11 7/8" X 2 1/2"	23 7/8" X 5 7/8" X 8 7/8" X 2 1/2"

**WAVE PAVER SIZES\*:**

3 7/8" X 12" X 4"
-------------------

**SONORASTONE® PAVER SIZES\*:**

12" X 12" X 2"	18" X 18" X 2"	24" X 24" X 2"
12" X 24" X 2"	18" X 24" X 2"	24" X 36" X 2"
12" X 36" X 2"	18" X 36" X 2"	

\*All sizes are nominal

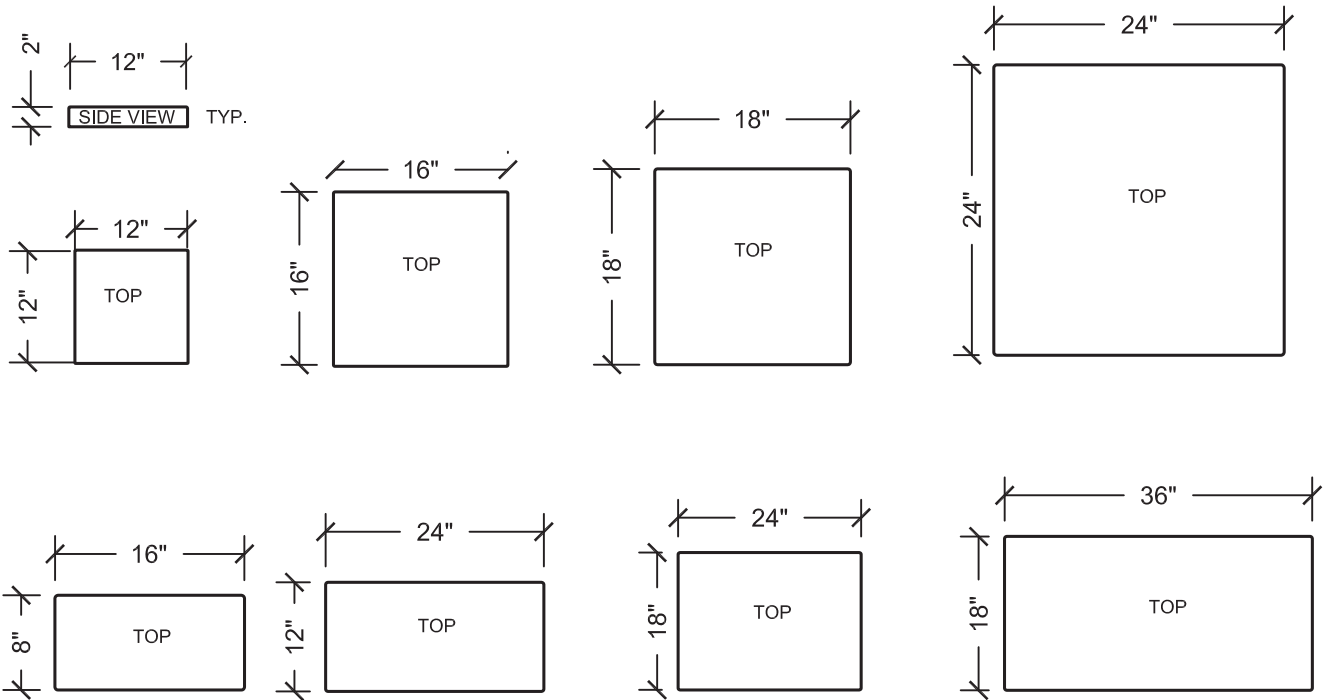

1. PAVERS SHOWN ABOVE SHALL BE 2" THICK; ALL SIZES ARE NOMINAL
2. PAVERS SHALL HAVE A MINIMUM COMPRESSIVE STRENGTH OF 5,000 PSI
3. PAVERS CAN BE MORTAR SET OR SAND SET
4. SANDBLAST FINISH - LIGHT, MEDIUM OR HEAVY
5. PAVERS ARE AVAILABLE IN TWELVE (12) STANDARD COLORS; CUSTOM COLORS AND SIZES MAY BE AVAILABLE UPON REQUEST
6. ALL SIDES HAVE DRAFT; SEE SPECIFICATIONS FOR TOLERANCES

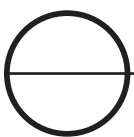

## CALARC PAVER - GENERAL DETAILS

SCALE: N.T.S.

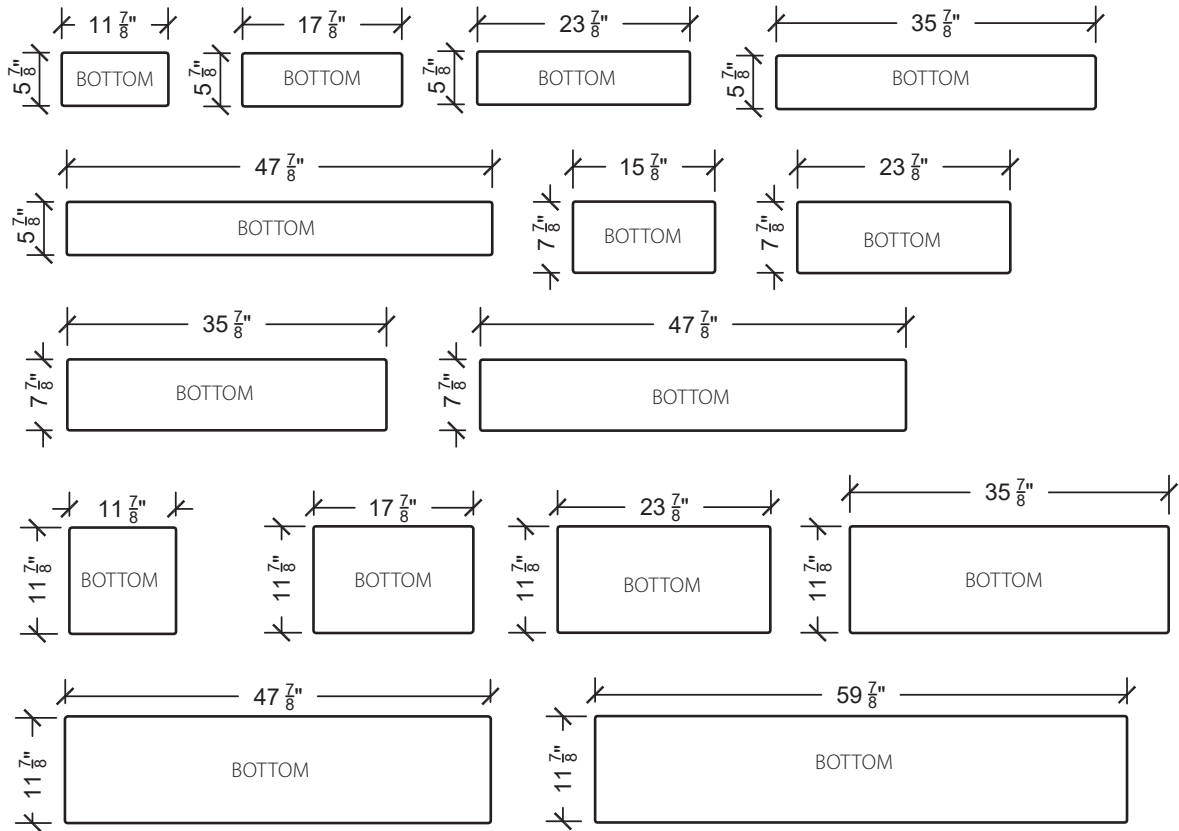
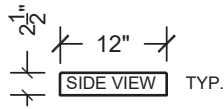

1. PAVERS SHOWN ABOVE SHALL BE 2 1/2" THICK; ALL SIZES ARE NOMINAL
2. PAVERS SHALL HAVE A MINIMUM COMPRESSIVE STRENGTH OF 5,000 PSI
3. PAVERS CAN BE MORTAR SET OR SAND SET
4. SANDBLAST FINISH - LIGHT, MEDIUM OR HEAVY
5. PAVERS ARE AVAILABLE IN TWELVE (12) STANDARD COLORS; CUSTOM COLORS AND SIZES MAY BE AVAILABLE UPON REQUEST
6. ALL SIDES HAVE DRAFT; SEE SPECIFICATIONS FOR TOLERANCES

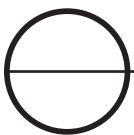

## LARGE SCALE CALARC PAVER - GENERAL DETAILS

SCALE: N.T.S.

**SIDE VIEW, TYP.**

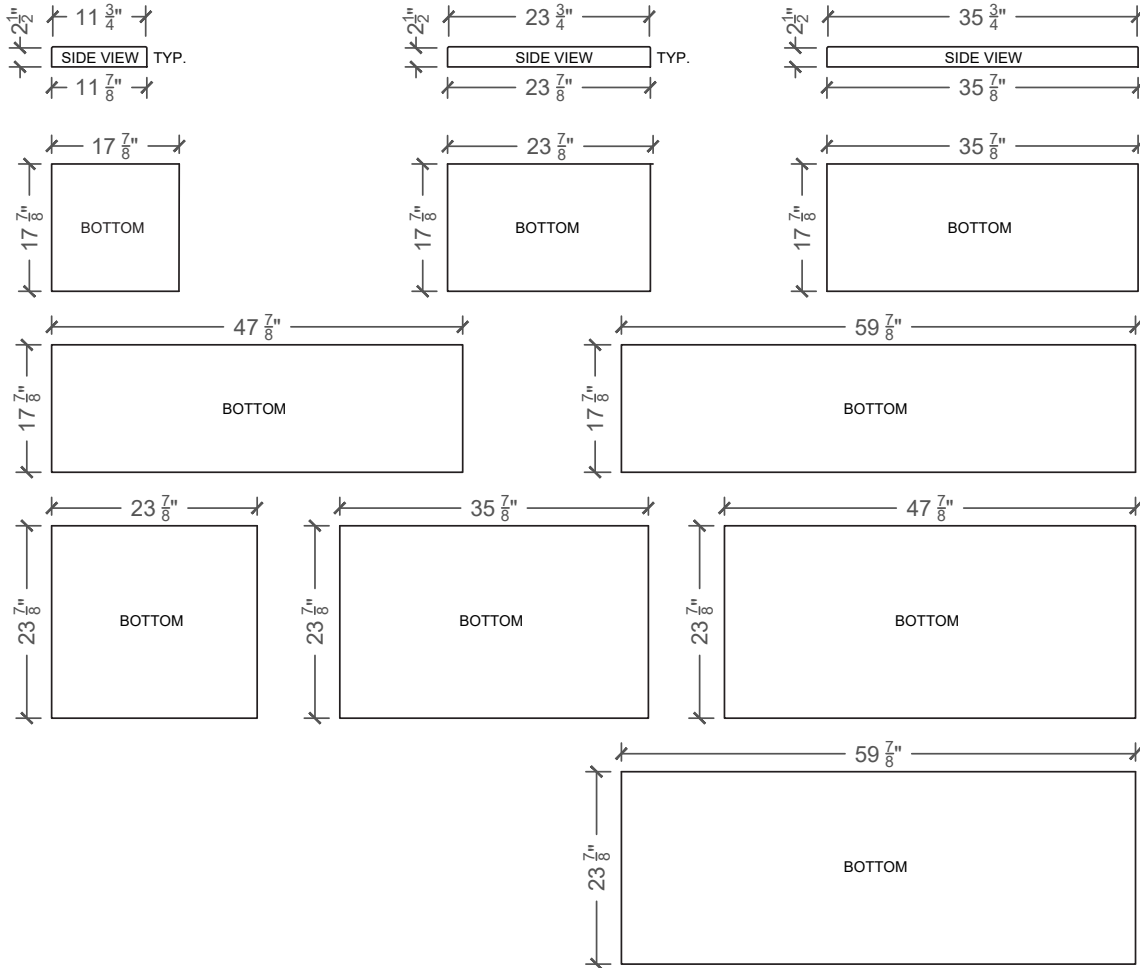

1. PAVERS SHOWN ABOVE SHALL BE  $2\frac{1}{2}''$  THICK; ALL SIZES ARE NOMINAL
2. PAVERS SHALL HAVE A MINIMUM COMPRESSIVE STRENGTH OF 5,000 PSI
3. PAVERS CAN BE MORTAR SET OR SAND SET
4. SANDBLAST FINISH - LIGHT, MEDIUM OR HEAVY
5. PAVERS ARE AVAILABLE IN TWELVE (12) STANDARD COLORS; CUSTOM COLORS AND SIZES MAY BE AVAILABLE UPON REQUEST
6. ALL SIDES HAVE DRAFT; SEE SPECIFICATIONS FOR TOLERANCES

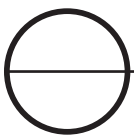

## LARGE SCALE CALARC PAVER - GENERAL DETAILS

SCALE: N.T.S.

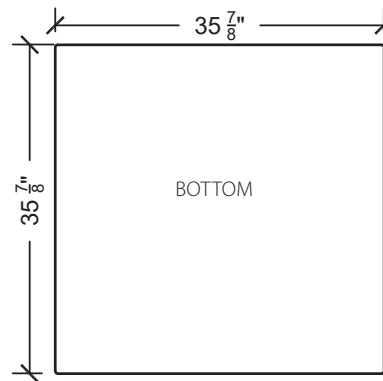
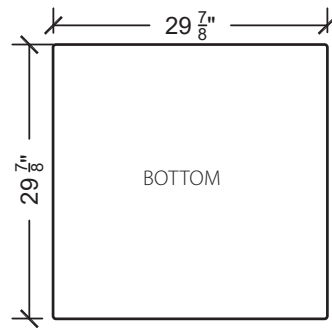
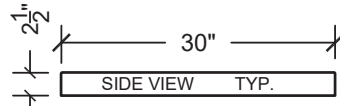

1. PAVERS SHOWN ABOVE SHALL BE 2 1/2" THICK; ALL SIZES ARE NOMINAL
2. PAVERS SHALL HAVE A MINIMUM COMPRESSIVE STRENGTH OF 5,000 PSI
3. PAVERS CAN BE MORTAR SET OR SAND SET
4. SANDBLAST FINISH - LIGHT, MEDIUM OR HEAVY
5. PAVERS ARE AVAILABLE IN TWELVE (12) STANDARD COLORS; CUSTOM COLORS AND SIZES MAY BE AVAILABLE UPON REQUEST
6. ALL SIDES HAVE DRAFT; SEE SPECIFICATIONS FOR TOLERANCES

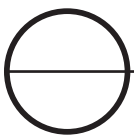

## LARGE SCALE CALARC PAVER - GENERAL DETAILS

SCALE: N.T.S.

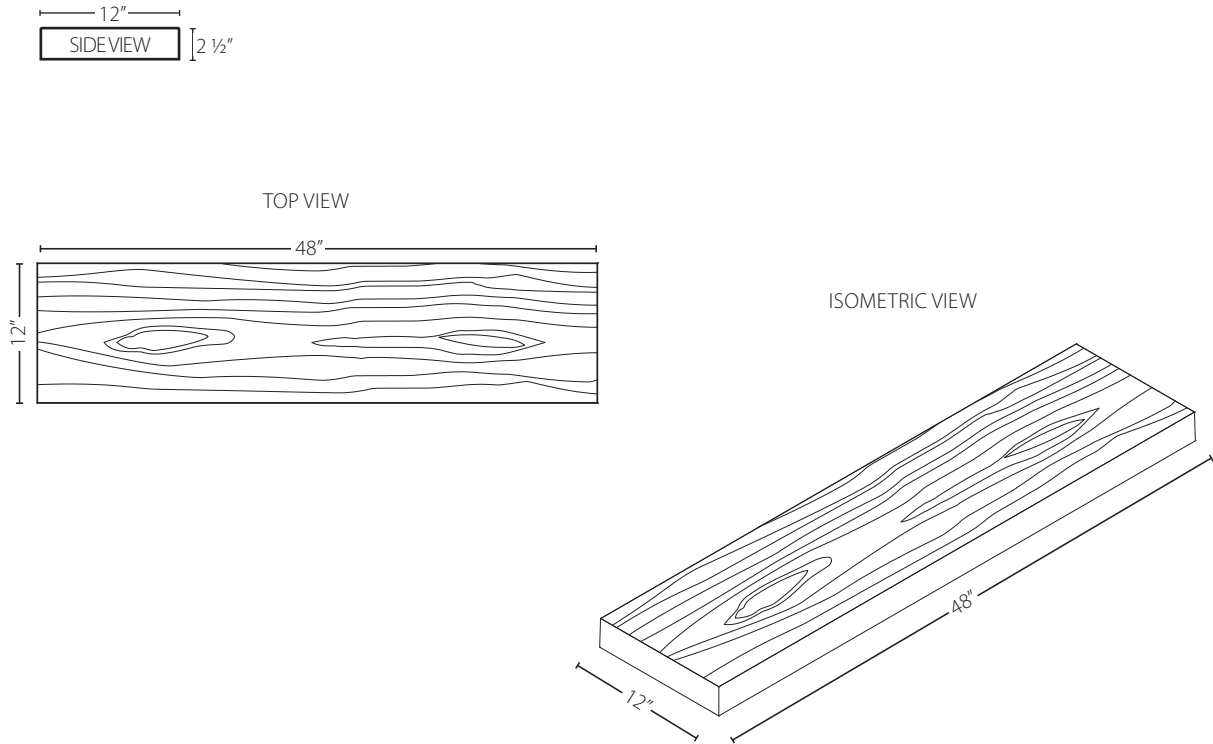

1. PAVERS SHOWN ABOVE SHALL BE 2 1/2" THICK; ALL SIZES ARE NOMINAL
2. PAVERS SHALL HAVE A MINIMUM COMPRESSIVE STRENGTH OF 5,000 PSI
3. PAVERS CAN BE MORTAR SET OR SAND SET
4. MADERASTONE® FINISH (WOOD GRAIN LOOK)
5. PAVERS ARE AVAILABLE IN TWELVE (12) STANDARD COLORS; CUSTOM COLORS AND SIZES MAY BE AVAILABLE UPON REQUEST
6. ALL SIDES HAVE DRAFT; SEE SPECIFICATIONS FOR TOLERANCES

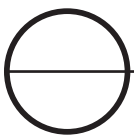

## MADERASTONE® PAVER - GENERAL DETAILS

SCALE: N.T.S.

TOP VIEW

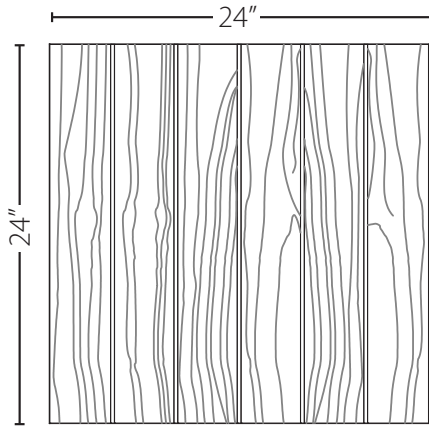

ISOMETRIC VIEW

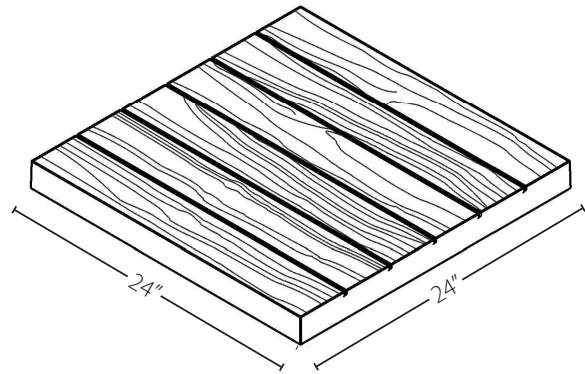

SIDE VIEW

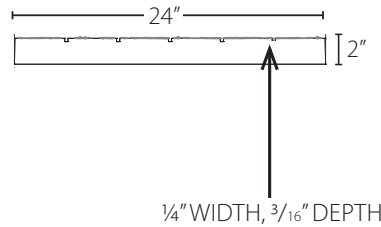

1. PAVERS SHOWN ABOVE SHALL BE 2" THICK; ALL SIZES ARE NOMINAL
2. PAVERS SHALL HAVE A MINIMUM COMPRESSIVE STRENGTH OF 5,000 PSI
3. PAVERS CAN BE MORTAR SET OR SAND SET
4. MADERASTONE® FINISH (WOOD GRAIN LOOK)
5. PAVERS ARE AVAILABLE IN TWELVE (12) STANDARD COLORS; CUSTOM COLORS AND SIZES MAY BE AVAILABLE UPON REQUEST
6. ALL SIDES HAVE DRAFT; SEE SPECIFICATIONS FOR TOLERANCES

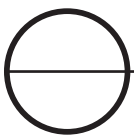

## MADERASTONE® PAVER - GENERAL DETAILS

SCALE: N.T.S.



TOP VIEW

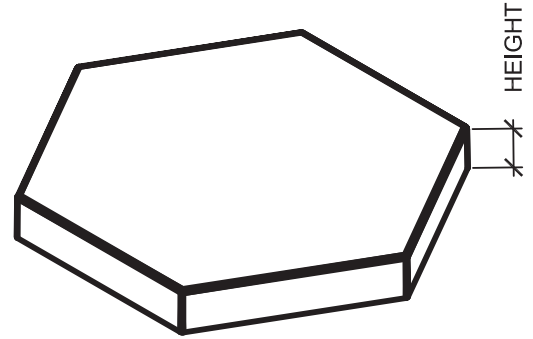
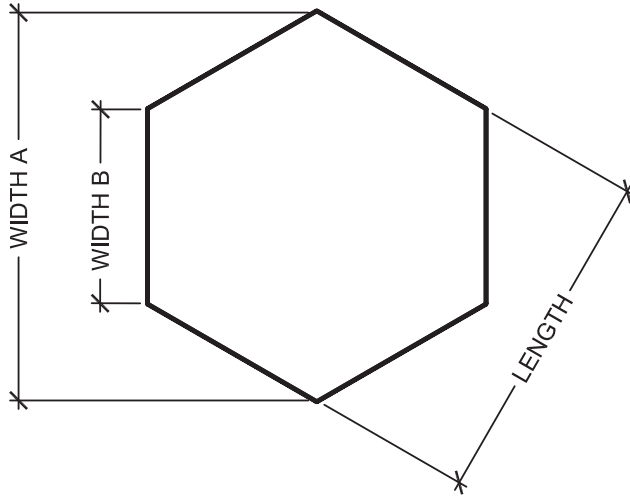

ISOMETRIC VIEW

SIDE VIEW

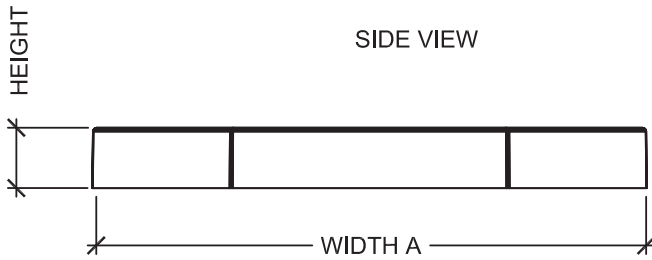

<u>WIDTH A</u>	<u>WIDTH B</u>	<u>LENGTH</u>	<u>HEIGHT</u>
18 ¼"	9 ⅛"	16"	2"
24"	12"	20 ½"	2 ½"
27 ½"	13 ¾"	24"	2 ½"

1. PAVERS SHOWN ABOVE SHALL BE 2" OR 2 ½" THICK; ALL SIZES ARE NOMINAL
2. PAVERS SHALL HAVE A MINIMUM COMPRESSIVE STRENGTH OF 5,000 PSI
3. PAVERS CAN BE MORTAR SET OR SAND SET
4. SANDBLAST FINISH - LIGHT, MEDIUM OR HEAVY
5. PAVERS ARE AVAILABLE IN TWELVE (12) STANDARD COLORS; CUSTOM COLORS AND SIZES MAY BE AVAILABLE UPON REQUEST
6. ALL SIDES HAVE DRAFT; SEE SPECIFICATIONS FOR TOLERANCES

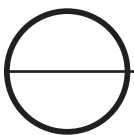

## HEXAGONAL PAVER - GENERAL DETAILS

SCALE: N.T.S.

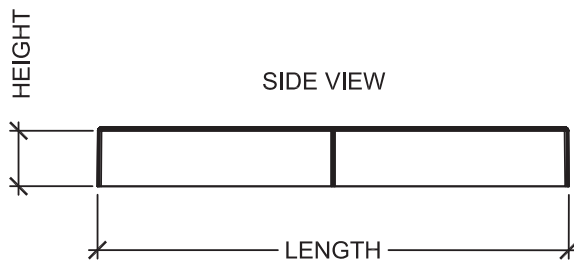
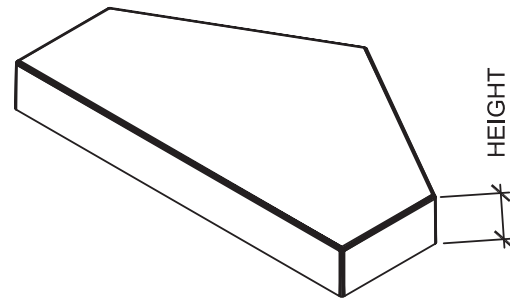
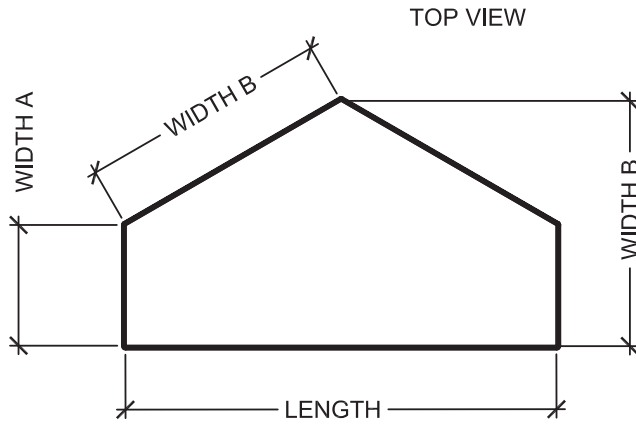

<u>WIDTH A</u>	<u>WIDTH B</u>	<u>LENGTH</u>	<u>HEIGHT</u>
4 1/2"	9 1/8"	16"	2"
6"	12"	20 1/2"	2 1/2"
7"	13 3/4"	24"	2 1/2"

1. PAVERS SHOWN ABOVE SHALL BE 2" OR 2 1/2" THICK; ALL SIZES ARE NOMINAL
2. PAVERS SHALL HAVE A MINIMUM COMPRESSIVE STRENGTH OF 5,000 PSI
3. PAVERS CAN BE MORTAR SET OR SAND SET
4. SANDBLAST FINISH - LIGHT, MEDIUM OR HEAVY
5. PAVERS ARE AVAILABLE IN TWELVE (12) STANDARD COLORS; CUSTOM COLORS AND SIZES MAY BE AVAILABLE UPON REQUEST
6. ALL SIDES HAVE DRAFT; SEE SPECIFICATIONS FOR TOLERANCES

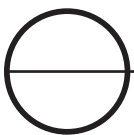

## HEXAGONAL POINT HALF PAVER - GENERAL DETAILS

SCALE: N.T.S.

TOP VIEW

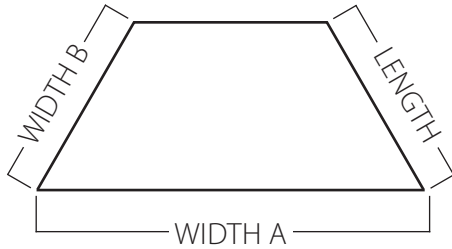

ISOMETRIC VIEW

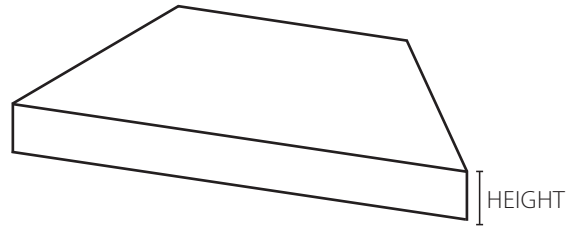

<u>WIDTH A</u>	<u>WIDTH B</u>	<u>LENGTH</u>	<u>HEIGHT</u>
18 ¼"	9 ⅛"	8"	2"
24"	12"	10 ¼"	2 ½"
27 ½"	13 ¾"	12"	2 ½"

1. PAVERS SHOWN ABOVE SHALL BE 2" OR 2 ½" THICK; ALL SIZES ARE NOMINAL
2. PAVERS SHALL HAVE A MINIMUM COMPRESSIVE STRENGTH OF 5,000 PSI
3. PAVERS CAN BE MORTAR SET OR SAND SET
4. SANDBLAST FINISH - LIGHT, MEDIUM OR HEAVY
5. PAVERS ARE AVAILABLE IN TWELVE (12) STANDARD COLORS; CUSTOM COLORS AND SIZES MAY BE AVAILABLE UPON REQUEST
6. ALL SIDES HAVE DRAFT; SEE SPECIFICATIONS FOR TOLERANCES

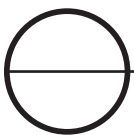

## HEXAGONAL FLAT HALF PAVER - GENERAL DETAILS

SCALE: N.T.S.

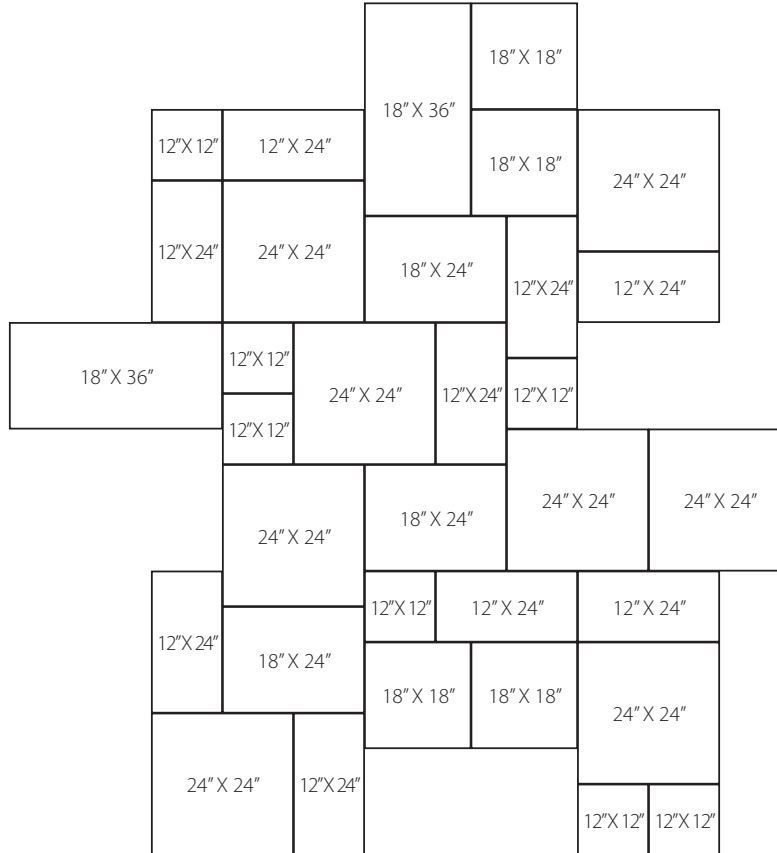

PATTERN REPEATS LEFT TO RIGHT, TOP TO BOTTOM		
ALLOW 3/16" NOMINAL JOINT		
<u>PATTERN INCLUDES:</u>		
7 PIECES	12" X 12" (1 SF EA)	7 SF
9 PIECES	12" X 24" (2 SF EA)	18 SF
8 PIECES	24" X 24" (4 SF EA)	32 SF
4 PIECES	18" X 18" (2.25 SF EA)	9 SF
3 PIECES	18" X 24" (3 SF EA)	9 SF
2 PIECES	18" X 36" (4.5 SF EA)	9 SF
TOTAL SF PER PATTERN:		84 SF

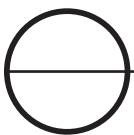

## ASHLAR PATTERN GUIDE

SCALE: N.T.S.

PATTERN INCLUDES:

- 12" X 12"
- 12" X 24"
- 24" X 24"

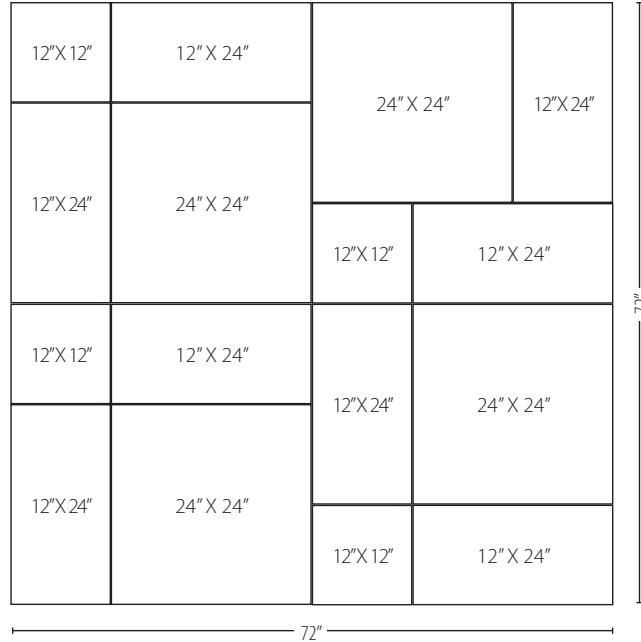

PATTERN INCLUDES:

- 18" X 18"
- 18" X 24"
- 18" X 36"

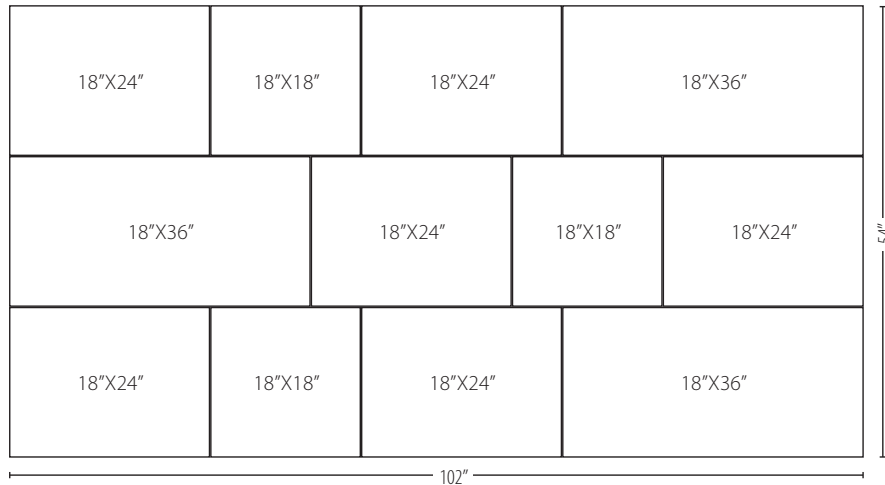

**RANDOM PATTERN GUIDE**  
SCALE: N.T.S.

PATTERN INCLUDES:

- 12" X 12"
- 12" X 24"
- 24" X 24"

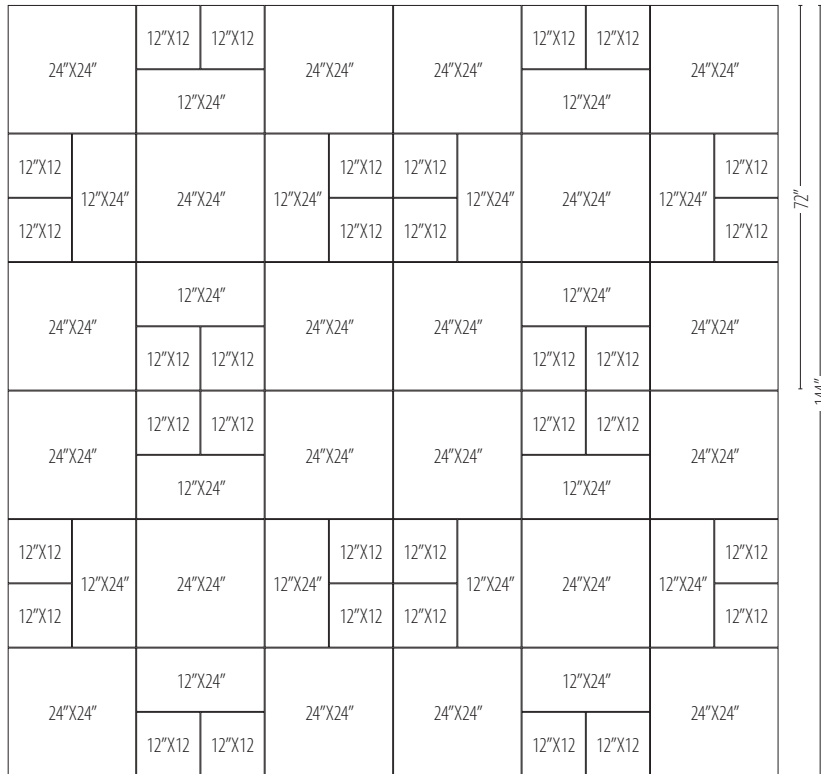

PATTERN INCLUDES:

- 12" X 12"
- 12" X 24"
- 24" X 24"

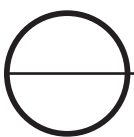
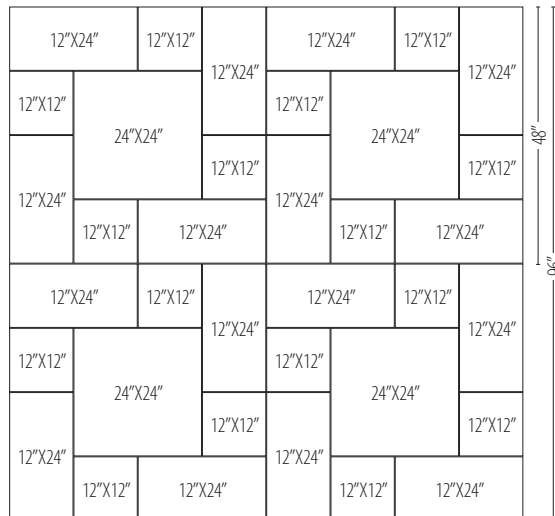

**RANDOM PATTERN GUIDE**

SCALE: N.T.S.

ISOMETRIC VIEW

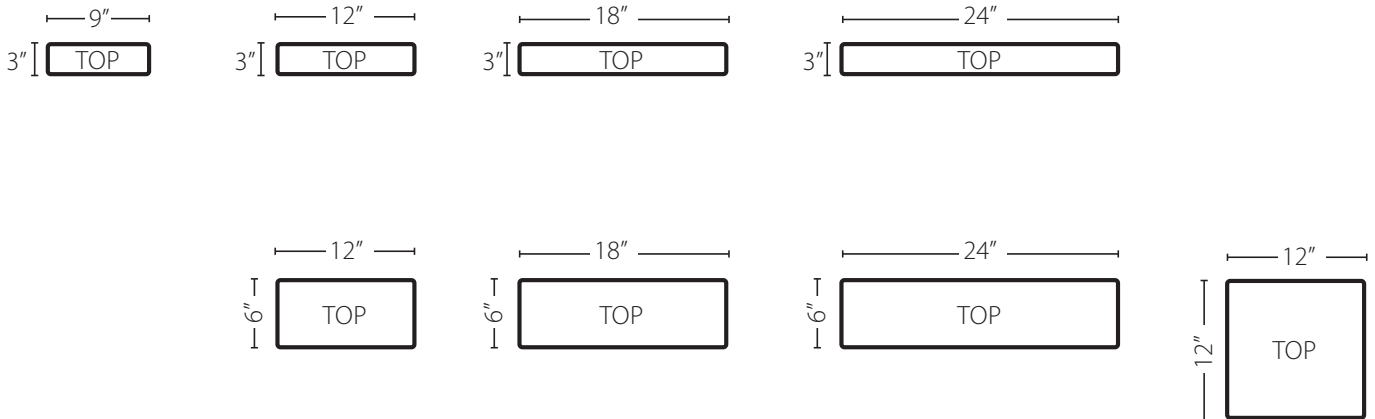
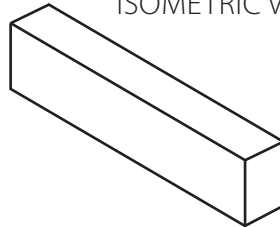

1. PAVERS SHOWN ABOVE SHALL BE 4" THICK; ALL SIZES ARE NOMINAL
2. PAVERS SHALL HAVE A MINIMUM COMPRESSIVE STRENGTH OF 5,000 PSI
3. PAVERS CAN BE MORTAR SET OR SAND SET
4. SANDBLAST FINISH - LIGHT, MEDIUM OR HEAVY
5. PAVERS ARE AVAILABLE IN TWELVE (12) STANDARD COLORS; CUSTOM COLORS AND SIZES MAY BE AVAILABLE UPON REQUEST
6. ALL SIDES HAVE DRAFT; SEE SPECIFICATIONS FOR TOLERANCES
7. PAVERS ARE MANUFACTURED WITH SPACING TABS TO PROVIDE UNIFORM JOINT SPACING

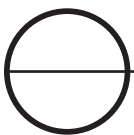

## NARROW MODULAR PAVER - GENERAL DETAILS

SCALE: N.T.S.

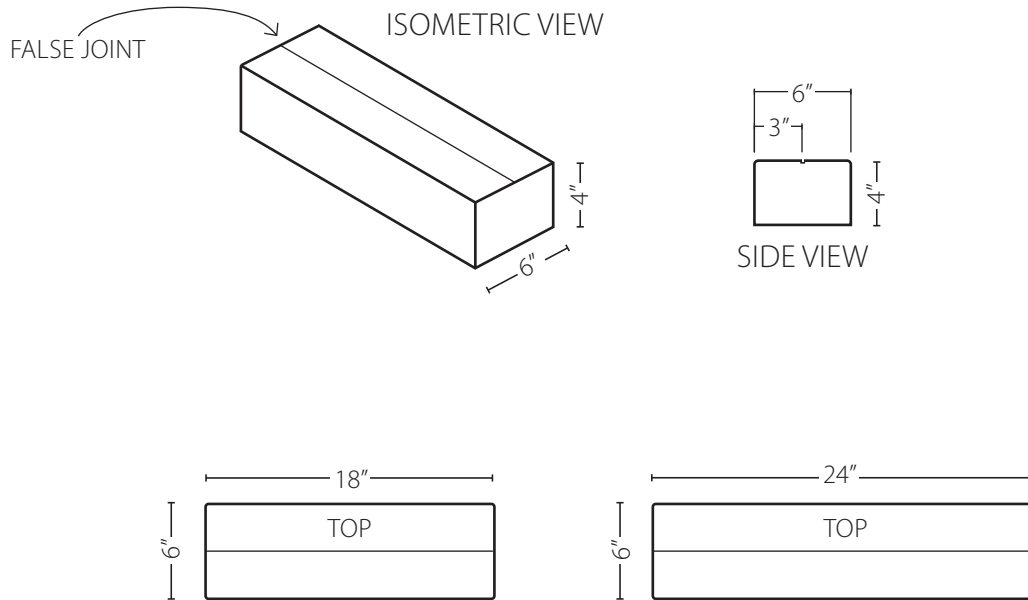

1. PAVERS SHOWN ABOVE SHALL BE 4" THICK; ALL SIZES ARE NOMINAL
2. PAVERS SHALL HAVE A MINIMUM COMPRESSIVE STRENGTH OF 5,000 PSI
3. PAVERS CAN BE MORTAR SET OR SAND SET
4. SANDBLAST FINISH - LIGHT, MEDIUM OR HEAVY
5. PAVERS ARE AVAILABLE IN TWELVE (12) STANDARD COLORS; CUSTOM COLORS AND SIZES MAY BE AVAILABLE UPON REQUEST
6. ALL SIDES HAVE DRAFT; SEE SPECIFICATIONS FOR TOLERANCES

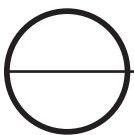

## NARROW MODULAR PAVER FALSE JOINT - DETAILS

SCALE: N.T.S.



NARROW MODULAR TILE

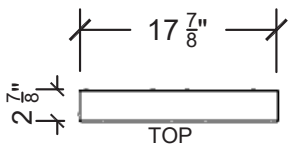
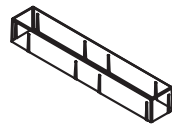
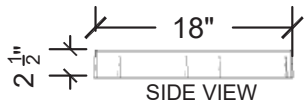
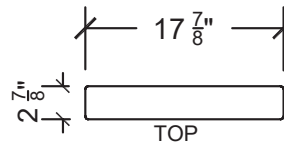
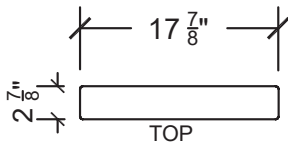
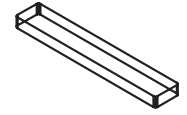
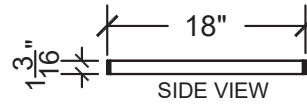
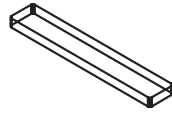
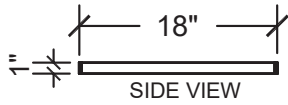

1. PAVERS SHOWN ABOVE SHALL BE 1" OR 1 3/16" THICK; ALL SIZES ARE NOMINAL
2. PAVERS SHALL HAVE A MINIMUM COMPRESSIVE STRENGTH OF 5,000 PSI
3. PAVERS MUST BE MORTAR SET
4. SANDBLAST FINISH - LIGHT, MEDIUM OR HEAVY
5. PAVERS ARE AVAILABLE IN TWELVE (12) STANDARD COLORS; CUSTOM COLORS AND SIZES MAY BE AVAILABLE UPON REQUEST
6. ALL SIDES HAVE DRAFT; SEE SPECIFICATIONS FOR TOLERANCES

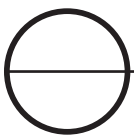

**NARROW MODULAR PAVER TILE - DETAILS**

SCALE: N.T.S.

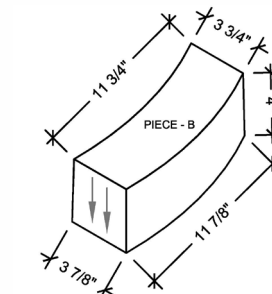
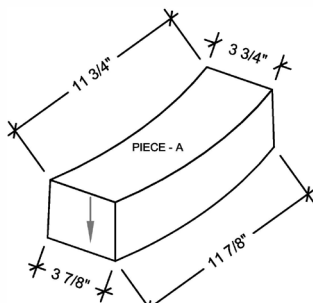
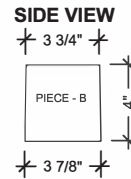
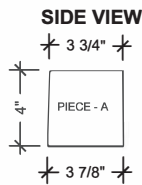
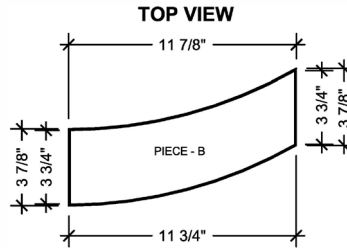
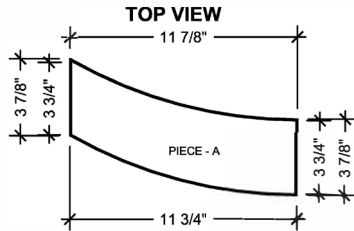

PIECE - A = ↓

PIECE - B = ↓↓

1. PAVERS SHOWN ABOVE SHALL BE 4" THICK; ALL SIZES ARE NOMINAL
2. PAVERS SHALL HAVE A MINIMUM COMPRESSIVE STRENGTH OF 5,000 PSI
3. PAVERS CAN BE MORTAR SET OR SAND SET
4. SANDBLAST FINISH - LIGHT, MEDIUM OR HEAVY
5. PAVERS ARE AVAILABLE IN TWELVE (12) STANDARD COLORS; CUSTOM COLORS AND SIZES MAY BE AVAILABLE UPON REQUEST
6. ALL SIDES HAVE DRAFT; SEE SPECIFICATIONS FOR TOLERANCES

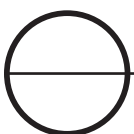

## WAVE PAVER PIECES A & B- GENERAL DETAILS

SCALE: N.T.S.

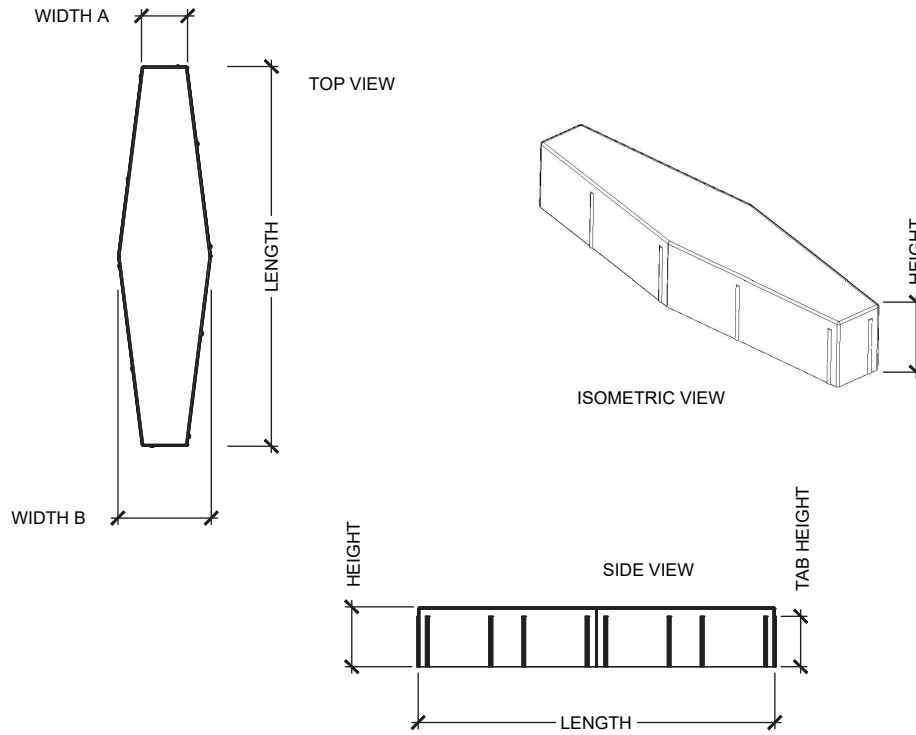

WIDTH A	WIDTH B	LENGTH	HEIGHT	TAB HEIGHT
2 <sup>7</sup> / <sub>8</sub> "	5 <sup>7</sup> / <sub>8</sub> "	23 <sup>7</sup> / <sub>8</sub> "	2 <sup>1</sup> / <sub>2</sub> "	1 <sup>7</sup> / <sub>8</sub> "
3 <sup>7</sup> / <sub>8</sub> "	7 <sup>7</sup> / <sub>8</sub> "	23 <sup>7</sup> / <sub>8</sub> "	2 <sup>1</sup> / <sub>2</sub> "	1 <sup>7</sup> / <sub>8</sub> "
5 <sup>7</sup> / <sub>8</sub> "	11 <sup>7</sup> / <sub>8</sub> "	23 <sup>7</sup> / <sub>8</sub> "	2 <sup>1</sup> / <sub>2</sub> "	1 <sup>7</sup> / <sub>8</sub> "

1. PAVERS SHOWN ABOVE SHALL BE 2 1/2" THICK; ALL SIZES ARE NOMINAL
2. PAVERS SHALL HAVE A MINIMUM COMPRESSIVE STRENGTH OF 5,000 PSI
3. PAVERS CAN BE MORTAR SET OR SAND SET
4. SANDBLAST FINISH - LIGHT, MEDIUM OR HEAVY
5. PAVERS ARE AVAILABLE IN TWELVE (12) STANDARD COLORS; CUSTOM COLORS AND SIZES MAY BE AVAILABLE UPON REQUEST
6. ALL SIDES HAVE DRAFT; SEE SPECIFICATIONS FOR TOLERANCES
7. PAVERS ARE MANUFACTURED WITH SPACING TABS TO PROVIDE UNIFORM JOINT SPACING

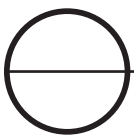

## DIAMOND PAVER - GENERAL DETAILS

SCALE: N.T.S.

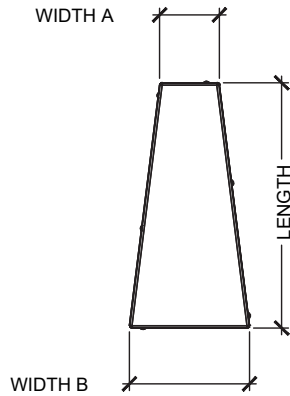

TOP VIEW

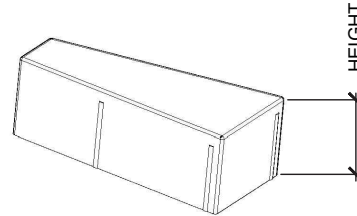

ISOMETRIC VIEW

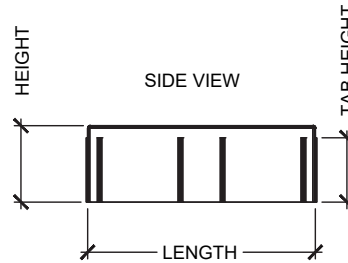

SIDE VIEW

WIDTH A	WIDTH B	LENGTH	HEIGHT	TAB HEIGHT
2 <sup>7</sup> / <sub>8</sub> "	5 <sup>7</sup> / <sub>8</sub> "	11 <sup>5</sup> / <sub>16</sub> "	2 <sup>1</sup> / <sub>2</sub> "	1 <sup>7</sup> / <sub>8</sub> "
3 <sup>7</sup> / <sub>8</sub> "	7 <sup>7</sup> / <sub>8</sub> "	11 <sup>5</sup> / <sub>16</sub> "	2 <sup>1</sup> / <sub>2</sub> "	1 <sup>7</sup> / <sub>8</sub> "
5 <sup>7</sup> / <sub>8</sub> "	11 <sup>7</sup> / <sub>8</sub> "	11 <sup>5</sup> / <sub>16</sub> "	2 <sup>1</sup> / <sub>2</sub> "	1 <sup>7</sup> / <sub>8</sub> "

1. PAVERS SHOWN ABOVE SHALL BE 2 1/2" THICK; ALL SIZES ARE NOMINAL
2. PAVERS SHALL HAVE A MINIMUM COMPRESSIVE STRENGTH OF 5,000 PSI
3. PAVERS CAN BE MORTAR SET OR SAND SET
4. SANDBLAST FINISH - LIGHT, MEDIUM OR HEAVY
5. PAVERS ARE AVAILABLE IN TWELVE (12) STANDARD COLORS; CUSTOM COLORS AND SIZES MAY BE AVAILABLE UPON REQUEST
6. ALL SIDES HAVE DRAFT; SEE SPECIFICATIONS FOR TOLERANCES
7. PAVERS ARE MANUFACTURED WITH SPACING TABS TO PROVIDE UNIFORM JOINT SPACING

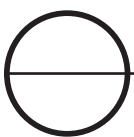

## DIAMOND POINT HALF PAVER - GENERAL DETAILS

SCALE: N.T.S.

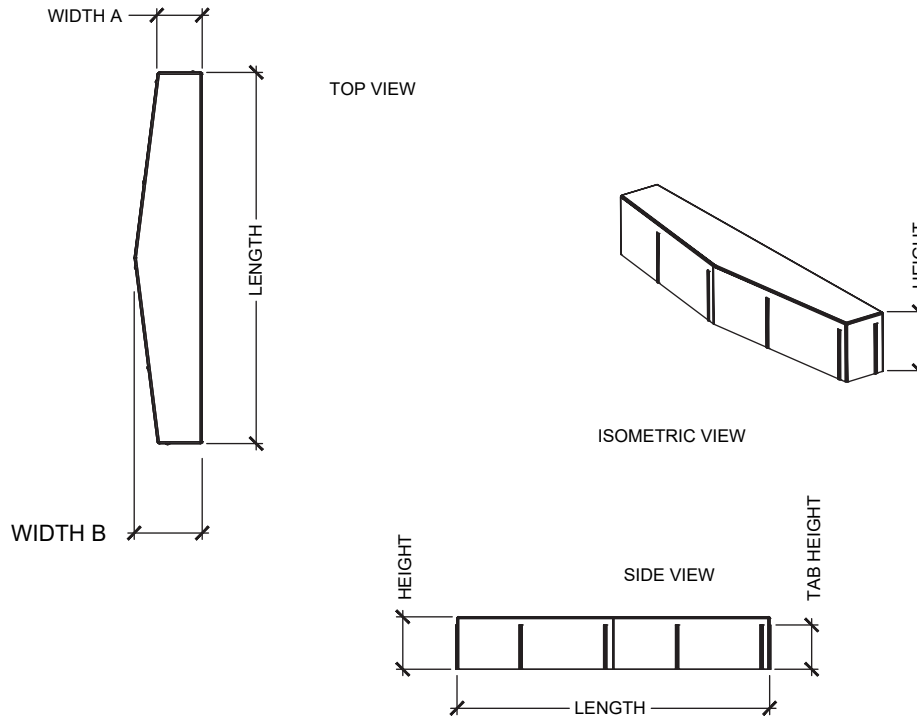

<u>WIDTH A</u>	<u>WIDTH B</u>	<u>LENGTH</u>	<u>HEIGHT</u>	<u>TAB HEIGHT</u>
2 <sup>7</sup> / <sub>8</sub> "	4 <sup>7</sup> / <sub>8</sub> "	23 <sup>7</sup> / <sub>8</sub> "	2 <sup>1</sup> / <sub>2</sub> "	1 <sup>7</sup> / <sub>8</sub> "
3 <sup>7</sup> / <sub>8</sub> "	5 <sup>7</sup> / <sub>8</sub> "	23 <sup>7</sup> / <sub>8</sub> "	2 <sup>1</sup> / <sub>2</sub> "	1 <sup>7</sup> / <sub>8</sub> "
5 <sup>7</sup> / <sub>8</sub> "	8 <sup>7</sup> / <sub>8</sub> "	23 <sup>7</sup> / <sub>8</sub> "	2 <sup>1</sup> / <sub>2</sub> "	1 <sup>7</sup> / <sub>8</sub> "

1. PAVERS SHOWN ABOVE SHALL BE 2 1/2" THICK; ALL SIZES ARE NOMINAL
2. PAVERS SHALL HAVE A MINIMUM COMPRESSIVE STRENGTH OF 5,000 PSI
3. PAVERS CAN BE MORTAR SET OR SAND SET
4. SANDBLAST FINISH - LIGHT, MEDIUM OR HEAVY
5. PAVERS ARE AVAILABLE IN TWELVE (12) STANDARD COLORS; CUSTOM COLORS AND SIZES MAY BE AVAILABLE UPON REQUEST
6. ALL SIDES HAVE DRAFT; SEE SPECIFICATIONS FOR TOLERANCES
7. PAVERS ARE MANUFACTURED WITH SPACING TABS TO PROVIDE UNIFORM JOINT SPACING

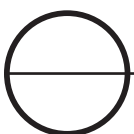

## DIAMOND FLAT HALF PAVER - GENERAL DETAILS

SCALE: N.T.S.

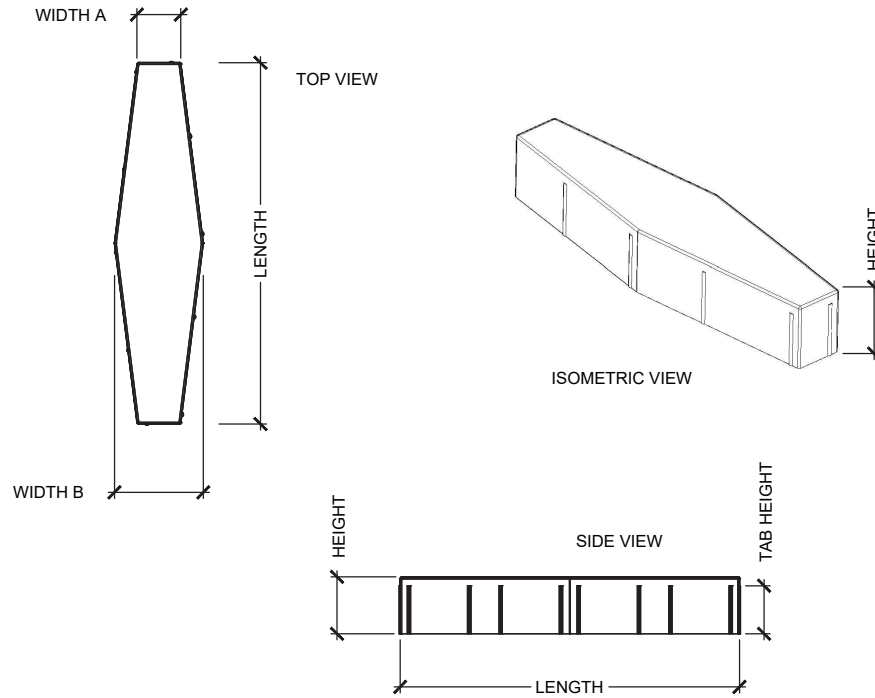

<u>WIDTH A</u>	<u>WIDTH B</u>	<u>LENGTH</u>	<u>HEIGHT</u>	<u>TAB HEIGHT</u>
2 <sup>7</sup> / <sub>8</sub> "	5 <sup>7</sup> / <sub>8</sub> "	23 <sup>7</sup> / <sub>8</sub> "	4"	3 <sup>3</sup> / <sub>8</sub> "
3 <sup>7</sup> / <sub>8</sub> "	7 <sup>7</sup> / <sub>8</sub> "	23 <sup>7</sup> / <sub>8</sub> "	4"	3 <sup>3</sup> / <sub>8</sub> "
5 <sup>7</sup> / <sub>8</sub> "	11 <sup>7</sup> / <sub>8</sub> "	23 <sup>7</sup> / <sub>8</sub> "	4"	3 <sup>3</sup> / <sub>8</sub> "

1. PAVERS SHOWN ABOVE SHALL BE 4"THICK; ALL SIZES ARE NOMINAL
2. PAVERS SHALL HAVE A MINIMUM COMPRESSIVE STRENGTH OF 5,000 PSI
3. PAVERS CAN BE MORTAR SET OR SAND SET
4. SANDBLAST FINISH - LIGHT, MEDIUM OR HEAVY
5. PAVERS ARE AVAILABLE IN TWELVE (12) STANDARD COLORS; CUSTOM COLORS AND SIZES MAY BE AVAILABLE UPON REQUEST
6. ALL SIDES HAVE DRAFT; SEE SPECIFICATIONS FOR TOLERANCES
7. PAVERS ARE MANUFACTURED WITH SPACING TABS TO PROVIDE UNIFORM JOINT SPACING

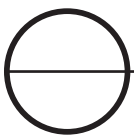

## DIAMOND PAVER - GENERAL DETAILS

SCALE: N.T.S.

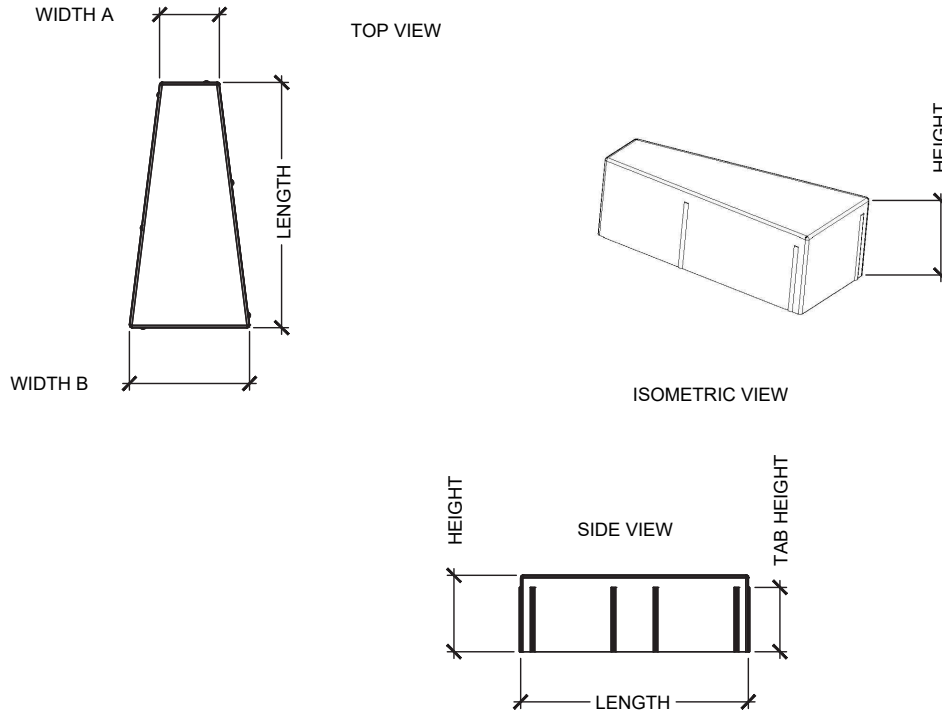

WIDTH A	WIDTH B	LENGTH	HEIGHT	TAB HEIGHT
2 <sup>7</sup> / <sub>8</sub> "	5 <sup>7</sup> / <sub>8</sub> "	11 <sup>15</sup> / <sub>16</sub> "	4"	3 <sup>3</sup> / <sub>8</sub> "
3 <sup>7</sup> / <sub>8</sub> "	7 <sup>7</sup> / <sub>8</sub> "	11 <sup>15</sup> / <sub>16</sub> "	4"	3 <sup>3</sup> / <sub>8</sub> "
5 <sup>7</sup> / <sub>8</sub> "	11 <sup>7</sup> / <sub>8</sub> "	11 <sup>15</sup> / <sub>16</sub> "	4"	3 <sup>3</sup> / <sub>8</sub> "

1. PAVERS SHOWN ABOVE SHALL BE 4" THICK; ALL SIZES ARE NOMINAL
2. PAVERS SHALL HAVE A MINIMUM COMPRESSIVE STRENGTH OF 5,000 PSI
3. PAVERS CAN BE MORTAR SET OR SAND SET
4. SANDBLAST FINISH - LIGHT, MEDIUM OR HEAVY
5. PAVERS ARE AVAILABLE IN TWELVE (12) STANDARD COLORS; CUSTOM COLORS AND SIZES MAY BE AVAILABLE UPON REQUEST
6. ALL SIDES HAVE DRAFT; SEE SPECIFICATIONS FOR TOLERANCES
7. PAVERS ARE MANUFACTURED WITH SPACING TABS TO PROVIDE UNIFORM JOINT SPACING

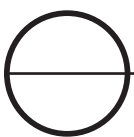

## DIAMOND POINT HALF PAVER - GENERAL DETAILS

SCALE: N.T.S.

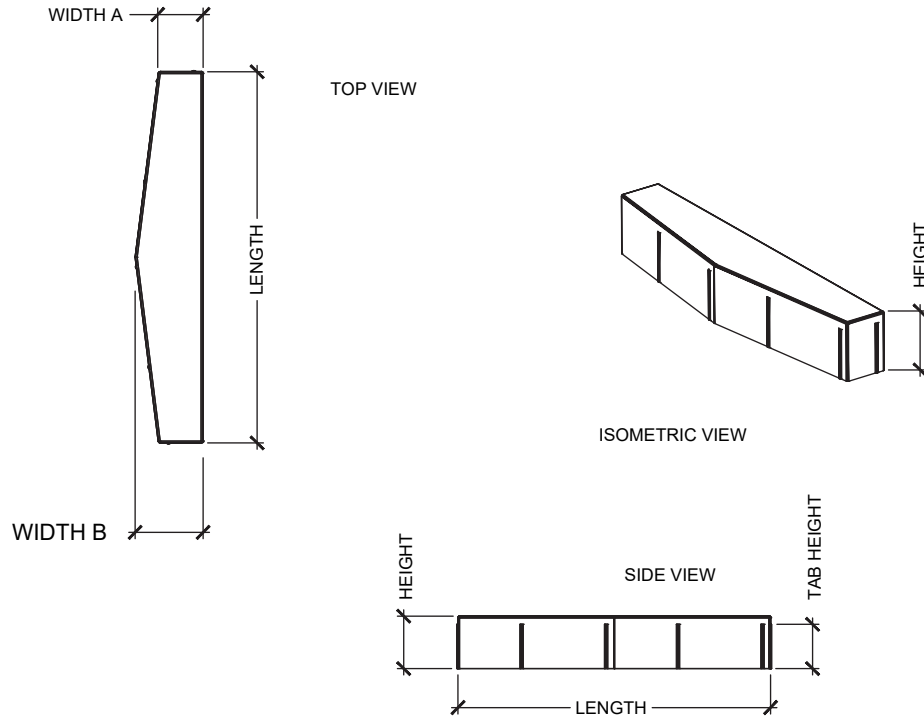

WIDTH A	WIDTH B	LENGTH	HEIGHT	TAB HEIGHT
2 <sup>7</sup> / <sub>8</sub> "	4 <sup>3</sup> / <sub>8</sub> "	23 <sup>7</sup> / <sub>8</sub> "	4"	3 <sup>3</sup> / <sub>8</sub> "
3 <sup>7</sup> / <sub>8</sub> "	5 <sup>7</sup> / <sub>8</sub> "	23 <sup>7</sup> / <sub>8</sub> "	4"	3 <sup>3</sup> / <sub>8</sub> "
5 <sup>7</sup> / <sub>8</sub> "	5 <sup>7</sup> / <sub>8</sub> "	23 <sup>7</sup> / <sub>8</sub> "	4"	3 <sup>3</sup> / <sub>8</sub> "

1. PAVERS SHOWN ABOVE SHALL BE 4" THICK; ALL SIZES ARE NOMINAL
2. PAVERS SHALL HAVE A MINIMUM COMPRESSIVE STRENGTH OF 5,000 PSI
3. PAVERS CAN BE MORTAR SET OR SAND SET
4. SANDBLAST FINISH - LIGHT, MEDIUM OR HEAVY
5. PAVERS ARE AVAILABLE IN TWELVE (12) STANDARD COLORS; CUSTOM COLORS AND SIZES MAY BE AVAILABLE UPON REQUEST
6. ALL SIDES HAVE DRAFT; SEE SPECIFICATIONS FOR TOLERANCES
7. PAVERS ARE MANUFACTURED WITH SPACING TABS TO PROVIDE UNIFORM JOINT SPACING

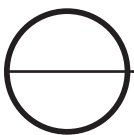

## DIAMOND FLAT HALF PAVER - GENERAL DETAILS

SCALE: N.T.S.



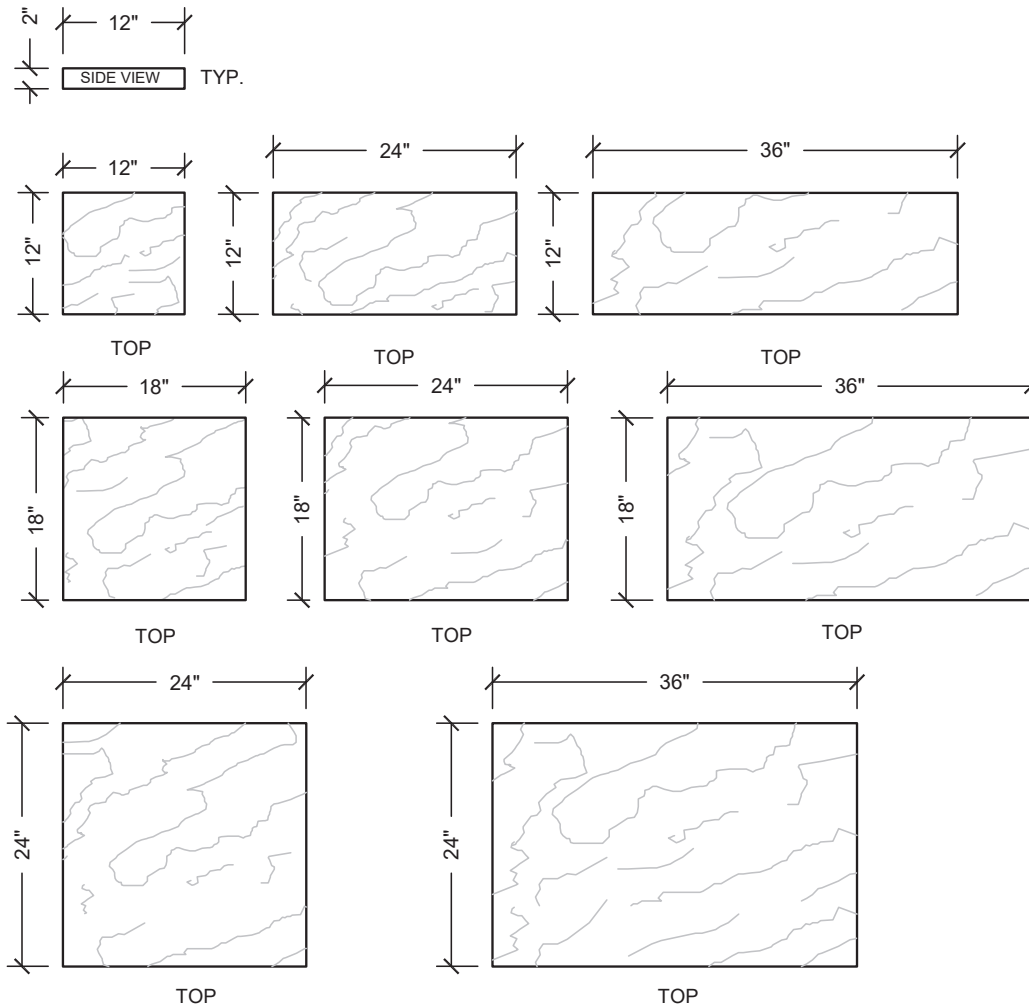

1. PAVERS SHOWN ABOVE SHALL BE 2" THICK; ALL SIZES ARE NOMINAL
2. PAVERS SHALL HAVE A MINIMUM COMPRESSIVE STRENGTH OF 5,000 PSI
3. PAVERS CAN BE MORTAR SET OR SAND SET
4. SONORASTONE® FINISH (SLATE LOOK)
5. PAVERS ARE AVAILABLE IN TWELVE (12) STANDARD COLORS; CUSTOM COLORS AND SIZES MAY BE AVAILABLE UPON REQUEST
6. ALL SIDES HAVE DRAFT; SEE SPECIFICATIONS FOR TOLERANCES

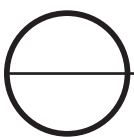

## SONORASTONE® PAVER - GENERAL DETAILS

SCALE: N.T.S.

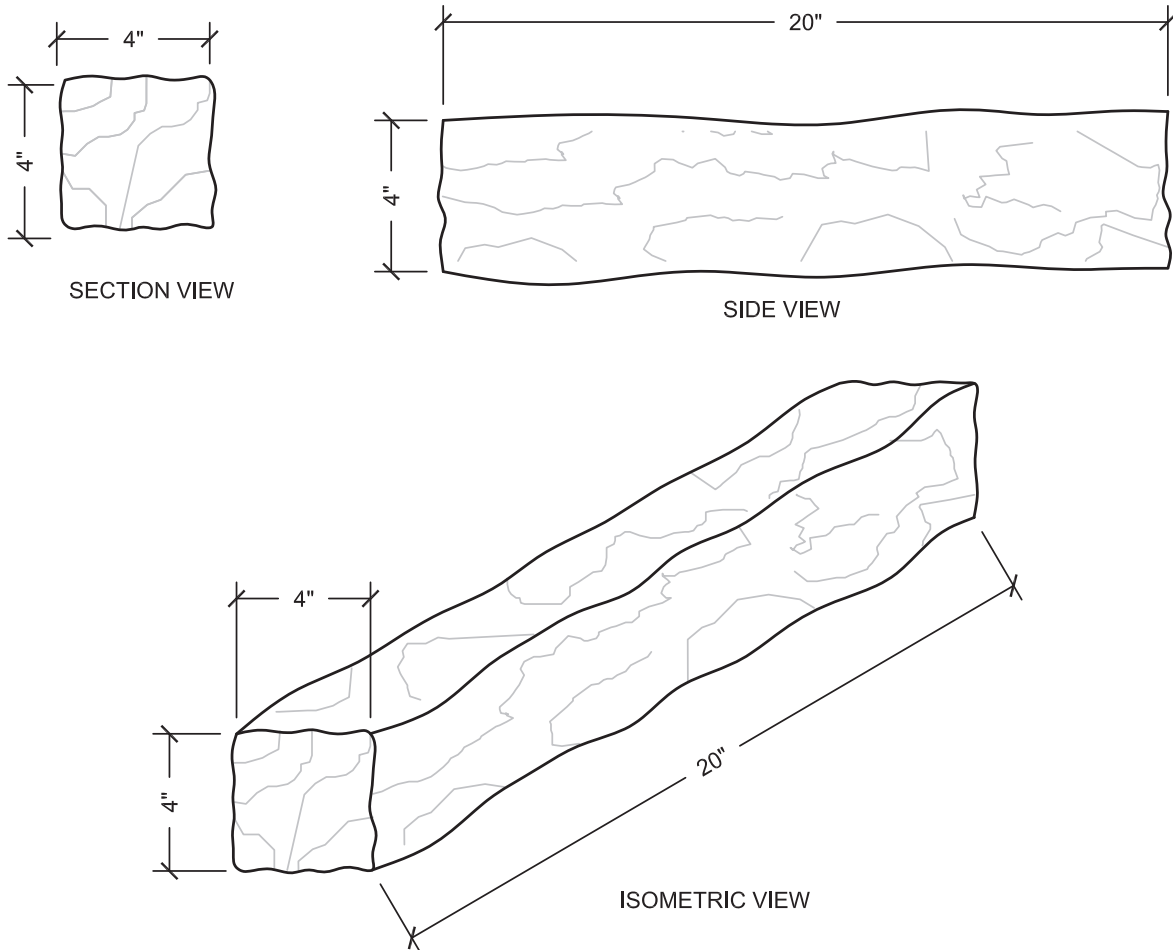

1. BORDERSTONE SHOWN ABOVE SHALL BE 4" THICK; ALL SIZES ARE NOMINAL
2. BORDERSTONE SHALL HAVE A MINIMUM COMPRESSIVE STRENGTH OF 5,000 PSI
3. BORDERSTONE CAN BE MORTAR SET OR SAND SET
4. SONORASTONE® FINISH (SLATE LOOK)
5. BORDERSTONE IS AVAILABLE IN TWELVE (12) STANDARD COLORS; CUSTOM COLORS AND SIZES MAY BE AVAILABLE UPON REQUEST
6. SEE SPECIFICATIONS FOR TOLERANCES

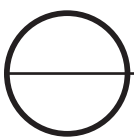

## BORDERSTONE - GENERAL DETAILS

SCALE: N.T.S.

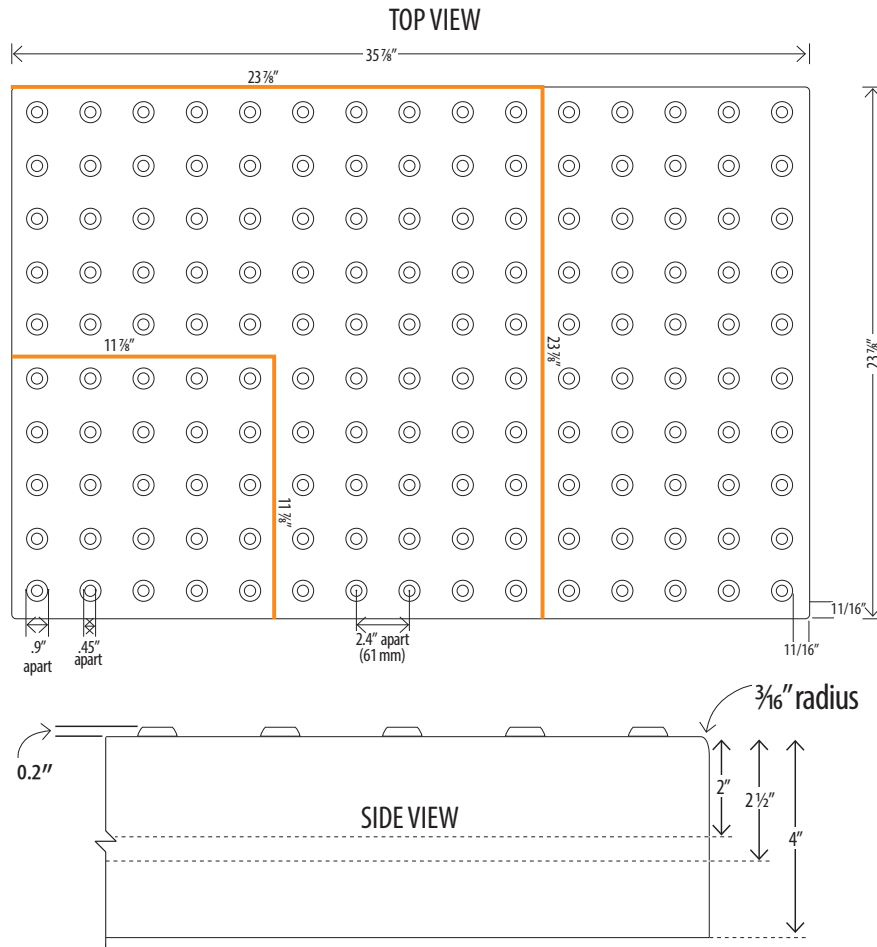

1. PAVERS SHOWN ABOVE SHALL BE 2", 2 1/2" OR 4" THICK; ALL SIZES ARE NOMINAL
2. PAVERS SHALL HAVE A MINIMUM COMPRESSIVE STRENGTH OF 5,000 PSI
3. PAVERS CAN BE SAND SET OR MORTAR SET
4. STIPPLED OR SANDBLAST FINISH - LIGHT, MEDIUM OR HEAVY
5. PAVERS ARE AVAILABLE IN TWELVE (12) STANDARD COLORS, FEDERAL YELLOW AND CHARCOAL; CUSTOM COLORS AND SIZES MAY BE AVAILABLE UPON REQUEST
6. ALL SIDES HAVE DRAFT; SEE SPECIFICATIONS FOR TOLERANCES
7. ORIENTATION OF DOMES ON CAST PAVERS IS +/- 1/16" OF SPECIFIED DIMENSIONS
8. ALL DIMENSIONS LISTED HERE ARE INTENDED TO MEET ADA SPECIFICATIONS
9. CONFIRM WITH LOCAL BUILDING CODES/OFFICIALS BEFORE INSTALLATION

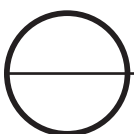

## TRUNCATED DOME PAVER - GENERAL DETAILS

SCALE: N.T.S.

TOP VIEW

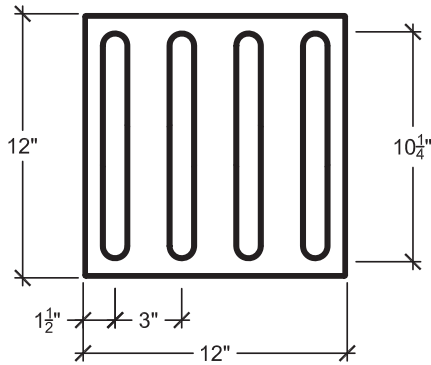

SIDE VIEW

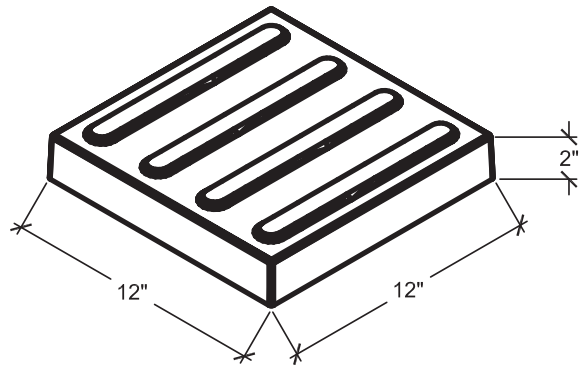
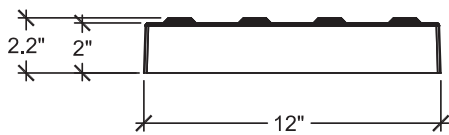

1. PAVERS SHOWN ABOVE SHALL BE 2"; ALL SIZES ARE NOMINAL
2. PAVERS SHALL HAVE A MINIMUM COMPRESSIVE STRENGTH OF 5,000 PSI
3. PAVERS CAN BE SAND SET OR MORTAR SET
4. STIPPLED OR SANDBLAST FINISH - LIGHT, MEDIUM OR HEAVY
5. PAVERS ARE AVAILABLE IN TWELVE (12) STANDARD COLORS, FEDERAL YELLOW AND CHARCOAL; CUSTOM COLORS AND SIZES MAY BE AVAILABLE UPON REQUEST
6. ALL SIDES HAVE DRAFT; SEE SPECIFICATIONS FOR TOLERANCES
7. ORIENTATION OF DOMES ON CAST PAVERS IS +/- 1/16" OF SPECIFIED DIMENSIONS
8. ALL DIMENSIONS LISTED HERE ARE INTENDED TO MEET ADA SPECIFICATIONS
9. CONFIRM WITH LOCAL BUILDING CODES/OFFICIALS BEFORE INSTALLATION

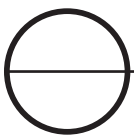

## TRUNCATED DOME PAVER - GENERAL DETAILS

SCALE: N.T.S.